

TECHNED BENELUX	Scope : USER MANUAL 2018-02 TNAML LED luminaire Zone 1 and 21				Date : 10-07-2019
	Rev. : 3	Checked by : JG.	Approved by : EG.	Page : 1 of 7	Procedure no. :

TECHNED BENELUX	Scope : USER MANUAL 2018-02 TNAML LED luminaire Zone 1 and 21				Date : 10-07-2019
	Rev. : 3	Checked by : JG.	Approved by : EG.	Page : 2 of 7	Procedure no. :

Marking:

TECHNED BENELUX	TechNed Benelux Veersteeg 15 4212LR The Netherlands	CE 0344 IP66
TNAML-LED...		Z1/21
S.No.		
INERIS 18 ATEX 0039X	U_n = 220-250VAC 50/60 HZ	
ⓂIIC Ex db eb mb op is IIC T6 Gb	P = ... W	
ⓂIIC Ex tb IIC T85°C Db	T.amb. -30°C / 55°C	
IECEx INE 18.0037X	Year of construction:	
Ex db eb mb op is IIC T6 Gb		
Ex tb IIC T85°C Db		

When using our AATB junction box for electrical connections (see also last page), depending the ignition temperature of the ambient (T4/T5/T6) the safe use is as shown in the table below, see also certificate of junctionbox CEC 10ATEX074

Temperatura ambiente massima Maximum ambient temperature	Classe di temperatura Temperature class	Temperatura superficiale massima "T" Maximum surface temperature "T"
+40°C	T6	80°C
+60°C	T5	95°C
+80°C	T4	130°C



1. Installation

Check that the luminaire is installed in an area with an ambient temperature within the temperatures that are mentioned on the label. If the temperatures is out of these limits, the life time of the luminaire can be reduced and the luminaire can no longer be considered safe for use in hazardous areas.

Also verify the following:

- Equipment is appropriate to the EPL/Zone requirements of the location
- Equipment group is correct
- Equipment temperature class is correct (only for gas)
- Equipment maximum surface temperature is correct (only for dust)
- Degree of protection (IP grade) of equipment is appropriate for the level of protection/group/conductivity. The TNAML luminaire is IP 66/68. IP 68 will occur only when the junction box is correctly filled, see procedure page 3.
- Equipment circuit identification is available and correct
- Enclosure and glass parts are undamaged
- There is no evidence of unauthorized modifications

When installing the TNAML luminaire range, the correct current limitation is to be considered. This protection should be a fuse or a circuit breaker minimum 4kA with a C type characteristic.

To define the quantity of luminaires per circuit, the table below can be considered.

Circuit breaker type	18 Watt (TNAML-LED18)	42 Watt (TNAML-LED42)
16A C	57luminaires	30 luminaires

Inrushcurrent information:

Type:	Inrush current I _{peak} (A)	½ value time Δt (μs)
TNAML-LED18	23	176
TNAML-LED42	40	173

When earth leakage protection is installed, it should be version **30mA**.

2. Connections :

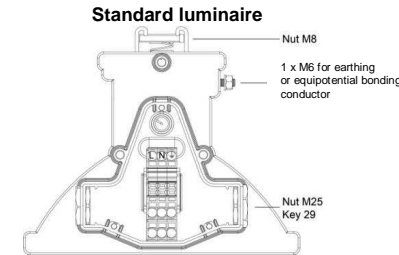

In the terminal box of the TNAML luminaires the terminal strip as shown above is installed.

Following connections can be made:

- L-N Connection terminals for power supply, range 220-250V 50/60Hz
- Earth connection terminal for internal earth wire.

Installation:

- Open the terminal box by using a Torx type T25 screw driver.
- Mount a nickel plated M25 cable gland, Ex e/Ex t complete with a nylon washer. Control if the cable diameter meets the sealing rings of the cable gland.
- Strip the cable and wires for min. 11 and max.13 mm. Mount the wires through the cable gland and connect the wires to the terminals, max 6 mm² flexible wires.
- Connect the wires as shown earlier in the termination drawing (L, N and GND).
- Tighten the cable gland according to the requirements instruction for this Ex specific gland.
- Close the terminal box after functional test and insulation resistance test, fill the terminal box with sealant material, included in packing, see instructions below (1 cartridge = volume in terminal box)

After making all connections but before filling the terminal box with sealant material, the following checks shall be carried out:

- Bolts, cable entry devices and blanking elements are of the correct type and are complete and tight
- Type of cable is appropriate
- There is no obvious damage to cables
- There is no evidence of ingress of water or dust in the terminal box in accordance with the IP rating
- Electrical connections are tight
- Earthing connections, including any supplementary earthing bonding connections are tight and conductors are of sufficient cross-section
- Fault loop impedance (TN systems) or earthing resistance (IT systems) is satisfactory
- Automatic electrical protective devices such as MCB/MCCB are set correctly (auto-reset not possible)
- Automatic electrical protective devices operate within permitted limits.
- Equipment is adequately protected against corrosion, weather, vibration and other adverse factors No undue accumulation of dust and dirt on the luminaire
- Electrical insulation is clean and dry

	Scope : USER MANUAL 2018-02 TNAML LED luminaire Zone 1 and 21				Date : 10-07-2019
	Rev. : 3	Checked by : JG.	Approved by : EG.	Page : 3 of 7	Procedure no. :

READ THE COMPLETE FILLING PROCEDURE MANUAL BELOW, or view (when possible and at safe location) on www.technedbenelux.nl the instruction video

Filling procedure for resin Ex e box (you will need a sealant applicator gun for a standard 310 ml cartridge)

1. The terminal box is closed
2. Install the tip onto the cartridge.
3. Cut the tip approx. 10 mm from the end.
4. Unscrew the M8 screw in the lid of the terminal box.
5. Install the cartridge in the sealant applicator gun and inject the tip into the M8 hole of the lid of the terminal box.
6. Press the complete amount of resin into the M8 hole of the lid of the terminal box.
7. Pull occasionally the tip around 10mm back so possible air inside the terminal box can be released to the atmosphere.
8. *The terminal box is filled completely when the whole cartridge is empty and then it is not possible to inject more material. (material will be forced back/out of the injection hole) All other methods of filling will not give a correct filling of the terminal box and consequently a reliable installation cannot be granted. (Warranties will not apply in this case)*
9. Below some pictures what will happen inside the terminal box



10. After a successful filling, install and tighten up the M8 screw.

4. Start up:

As soon as the power is switched on, the LEDs will ignite within 2 seconds, the time can be influenced by the ambient temperature. **Never switch on the luminaire before all installation is completed and insulation test performed.**

5. Insulation resistance test:

In case of insulation resistance test, this can be done with test(example: Megger®) at 500VDC between line and earth or neutral and earth.

Never between line and neutral !!!!!!!!!!!

During production, the luminaire has had a dielectric test of 1800V for 1 second.

6. Dismantling

When removing the luminaire, the same precautions apply as those observed when mounting the luminaire.

7. Use, special conditions:

- The lighting compartment of the luminaire shall never be opened to avoid humidity close to the encapsulated LED strip(s)
- The length of the flame proof joints of the ballast housing are greater than the values stated in the tables of the standard IEC/EN 60079-1. The flame proof joints are intended to be repaired.
- The user shall connect the free extremity of cable either in a non-explosive atmosphere, or in an enclosure protected by a recognised protection mode adapted for the area.

	Scope : USER MANUAL 2018-02 TNAML LED luminaire Zone 1 and 21				Date : 10-07-2019
	Rev. : 3	Checked by : JG.	Approved by : EG.	Page : 4 of 7	Procedure no. :

8. Inspection and Maintenance:

The light source of this luminaire is not replaceable; when the light source reaches its end of life the whole luminaire shall be replaced. The luminaire is sealed for life and cannot be opened for re-lamping etc.. Therefore maintenance as described in the standard EN/IEC 60079-17, is applicable through **only visual inspections** as required in view to check correct operation and any damage of the luminaire, according to the following checklist (see EN/IEC 60079-17):

Equipment is appropriate to the EPL/Zone requirements of the location

1. Degree of protection (IP grade) of equipment is appropriate for the level of protection/group/conductivity
2. Equipment circuit identification is available
3. Enclosure and glass parts are undamaged
4. There is no evidence of unauthorized modifications
5. Bolts, cable entry devices and blanking elements are of the correct type and are complete and tight
6. There is no obvious damage to cables
7. Earthing connections, including any supplementary earthing bonding connections are tight and conductors are of sufficient cross-section
8. Equipment is adequately protected against corrosion, weather, vibration and other adverse factors, No undue accumulation of dust and dirt

9. Standards IEC according certificate

- | | | | |
|----------------|----------------|----------------|--------|
| - IEC 60079-0 | : 2011 | - IEC 60079-1 | : 2014 |
| - IEC 60079-18 | : 2014/A1:2017 | - IEC 60079-28 | : 2015 |
| - IEC 60079-7 | : 2015/A1:2017 | - IEC 60079-31 | : 2013 |

Standards EN according certificate

- | | | | |
|------------------|------------------|---------------|--------|
| - EN 60079-0 | : 2012/ A11:2013 | - EN 60079-1 | : 2014 |
| - EN IEC 60079-7 | : 2015/ A1: 2018 | - EN 60079-28 | : 2015 |
| - EN 60079-18 | : 2015/ A1:2017 | - EN 60079-31 | : 2014 |

10. Mounting of the luminaire

- Remove the luminaire from the carton packing.
- Control if the luminaire is mechanically damaged.
- Install the luminaire to the construction, see drawings / pictures below.

The mounting sets for ceiling mounting, pole mounting and mounting on ship can be delivered optionally and need to be ordered separately.

TNAML-LED42



TNAML-LED18



TECHNE BENELUX	Scope : USER MANUAL 2018-02 TNAML LED luminaire Zone 1 and 21				Date : 10-07-2019
	Rev. : 3	Checked by : JG.	Approved by : EG.	Page : 5 of 7	Procedure no. :

Ceiling mounting:

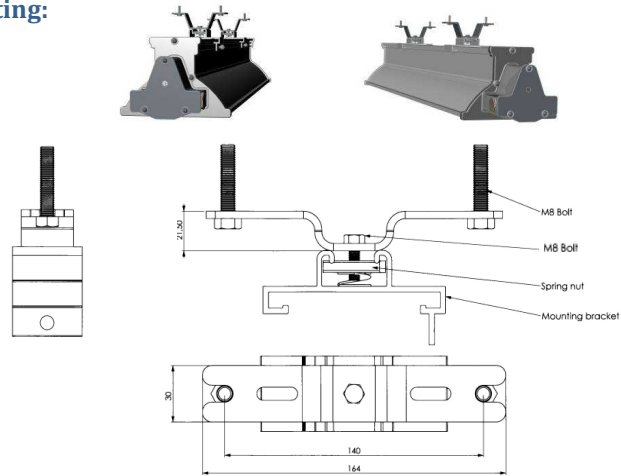

Pole mounting:

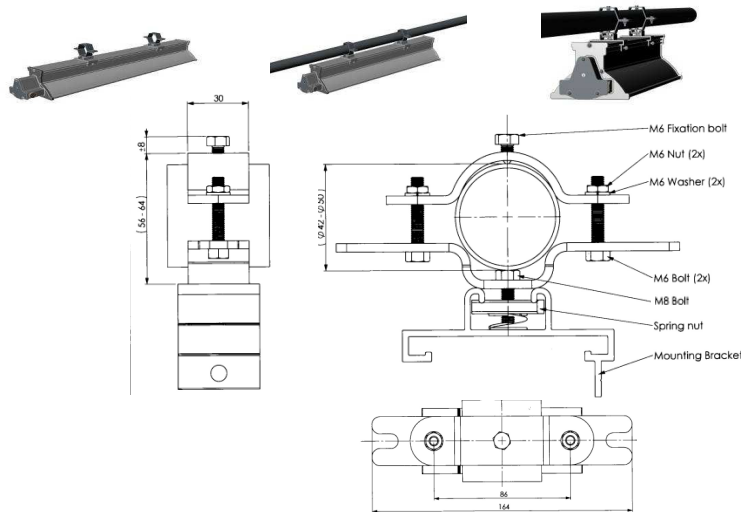

Pendant



TECHNE BENELUX	Scope : USER MANUAL 2018-02 TNAML LED luminaire Zone 1 and 21				Date : 10-07-2019
	Rev. : 3	Checked by : JG.	Approved by : EG.	Page : 6 of 7	Procedure no. :

Mounting on steel plate of ship:

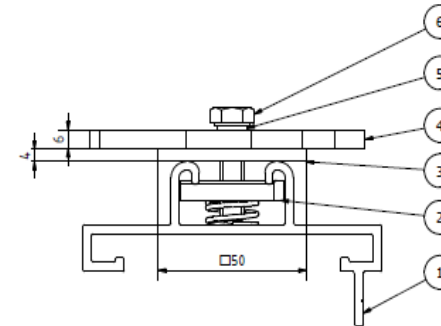

1. Suspension profile (part of the luminaire)
2. Sliding/spring nut
3. Plate Korrex or HPME
4. Steel plate of ship
5. Ring Duba M8
6. Bolt M8 x 30

The spring nut (component part 2 on the drawing) which is delivered with the luminaire (attached on the luminaire as delivered) has to be removed and replaced by the spring nut which is delivered as part of the mounting on steel plate of ship set.

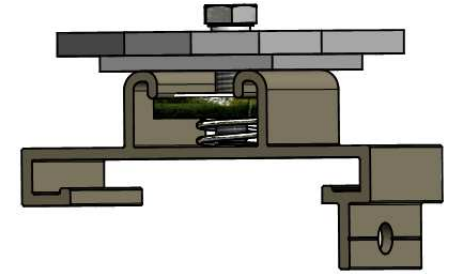

MANUAL AATB

AATB Views (1:4)

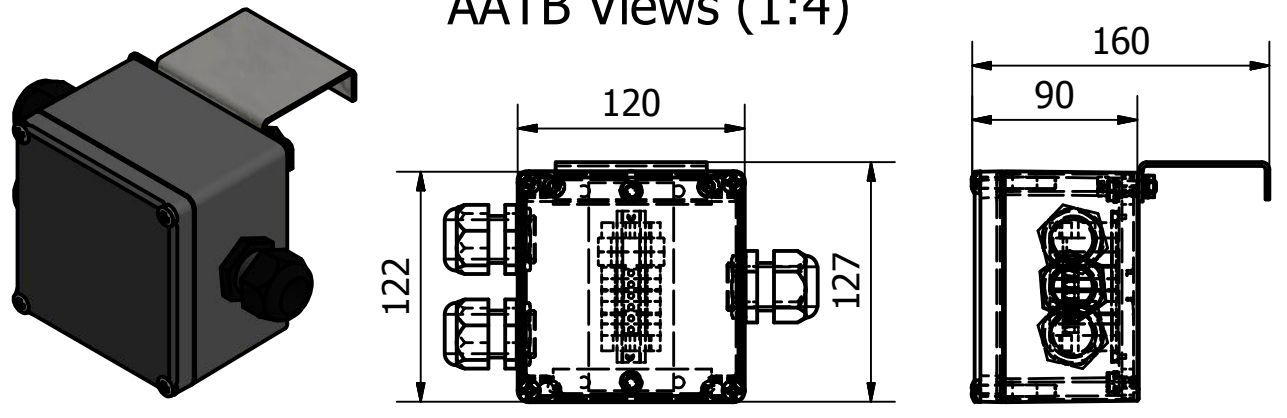

AATB attached to TNAML (1:8)

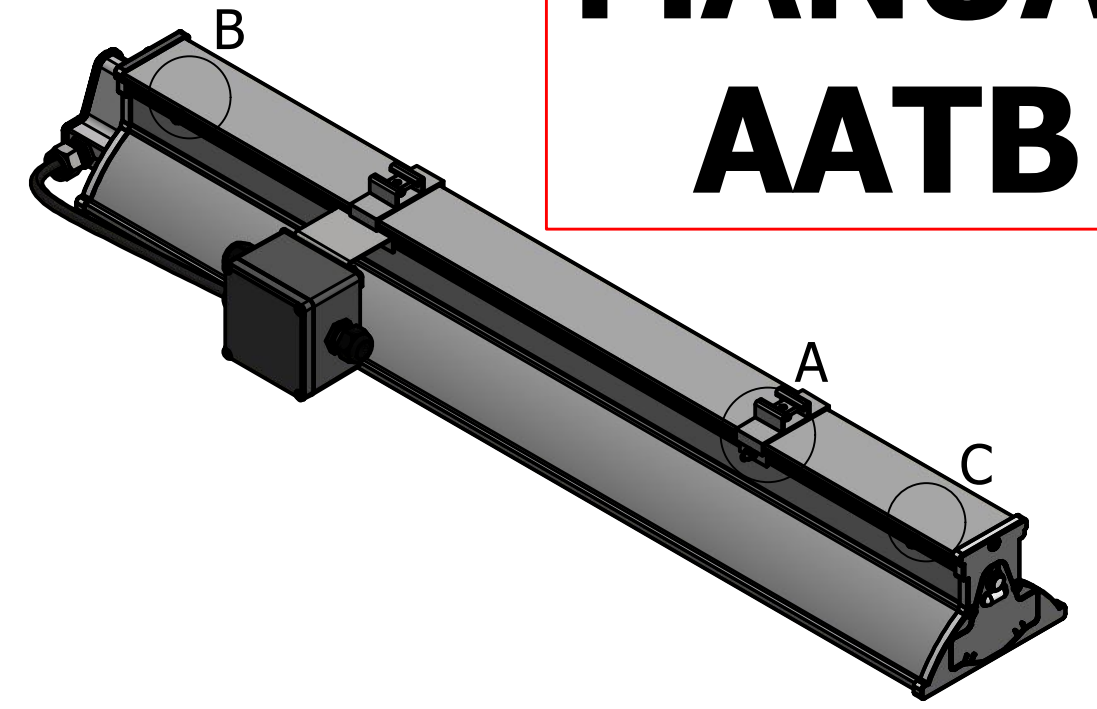

Installation wire AATB (Standard) (1:2)

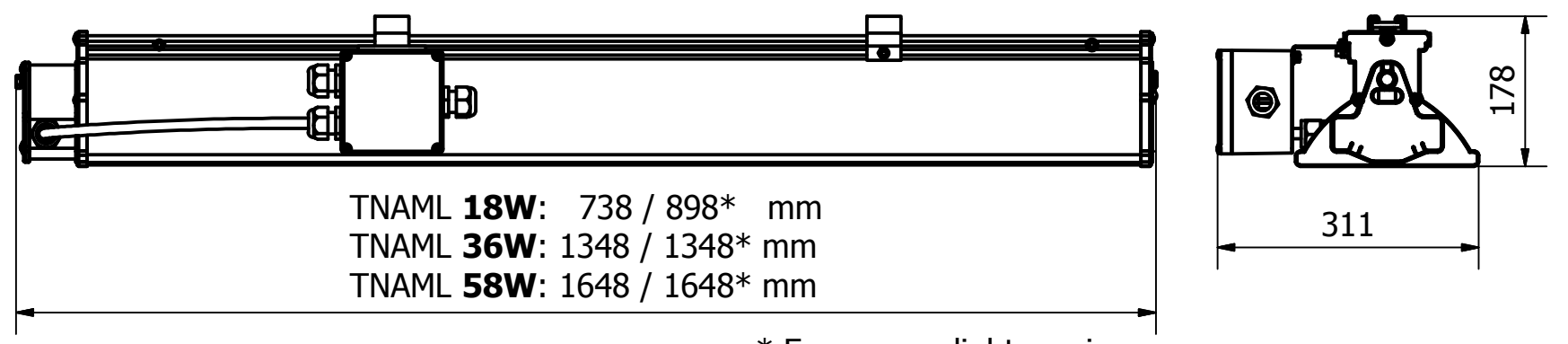
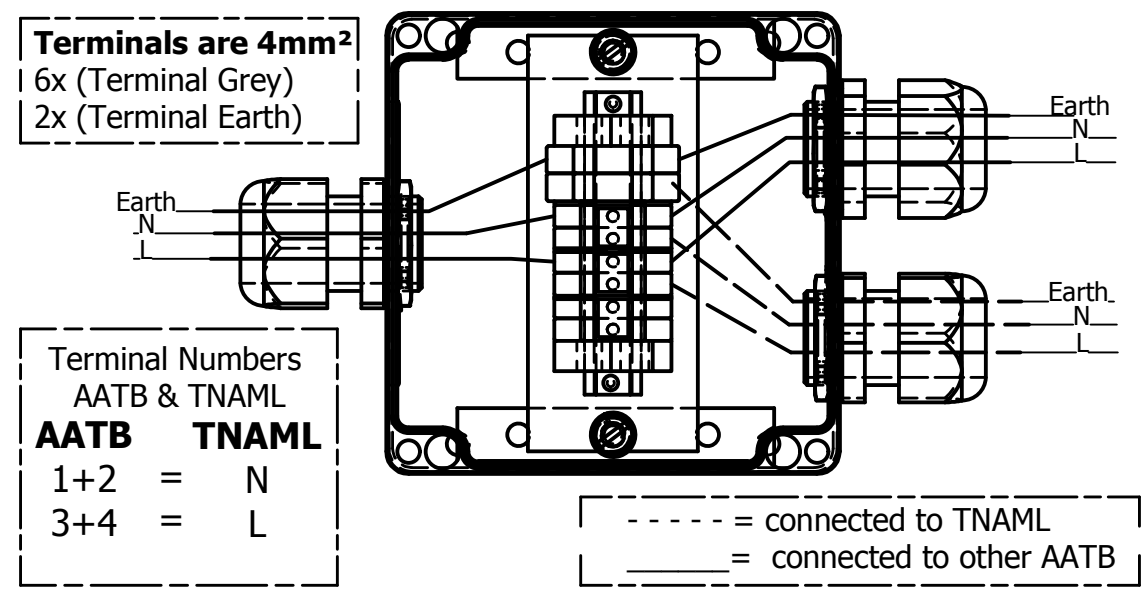

Installation wire AATB (Emergency light) (1:2)

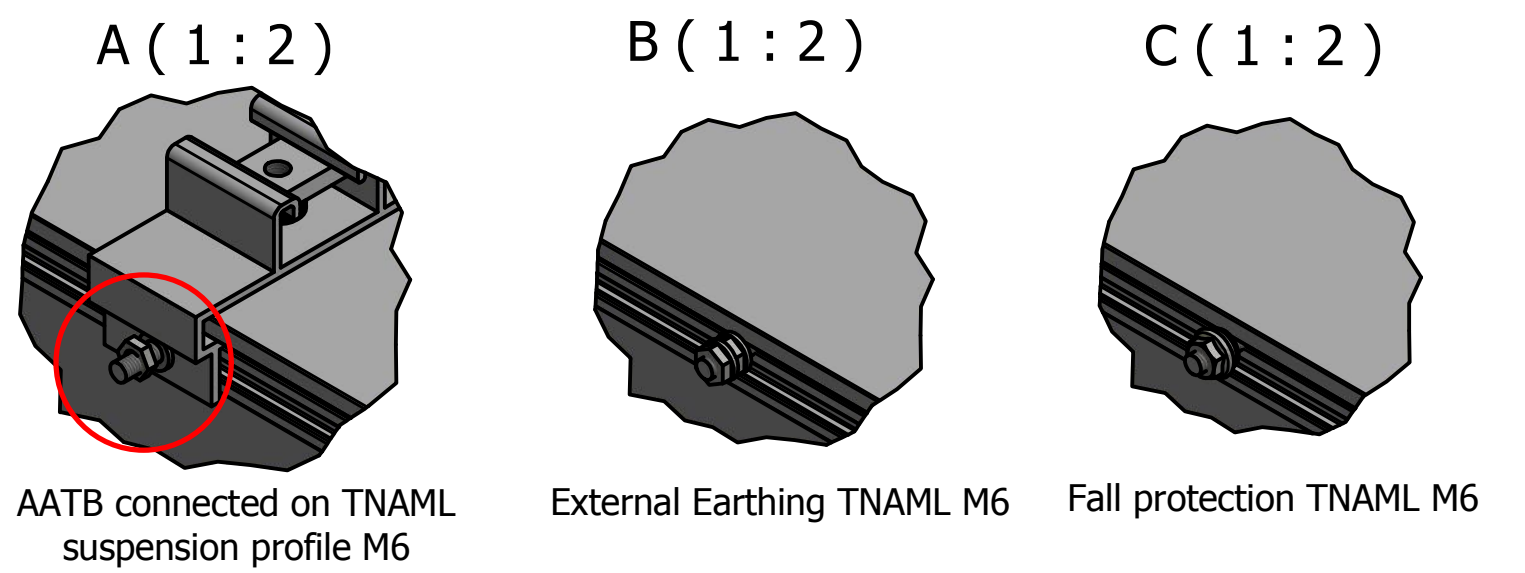
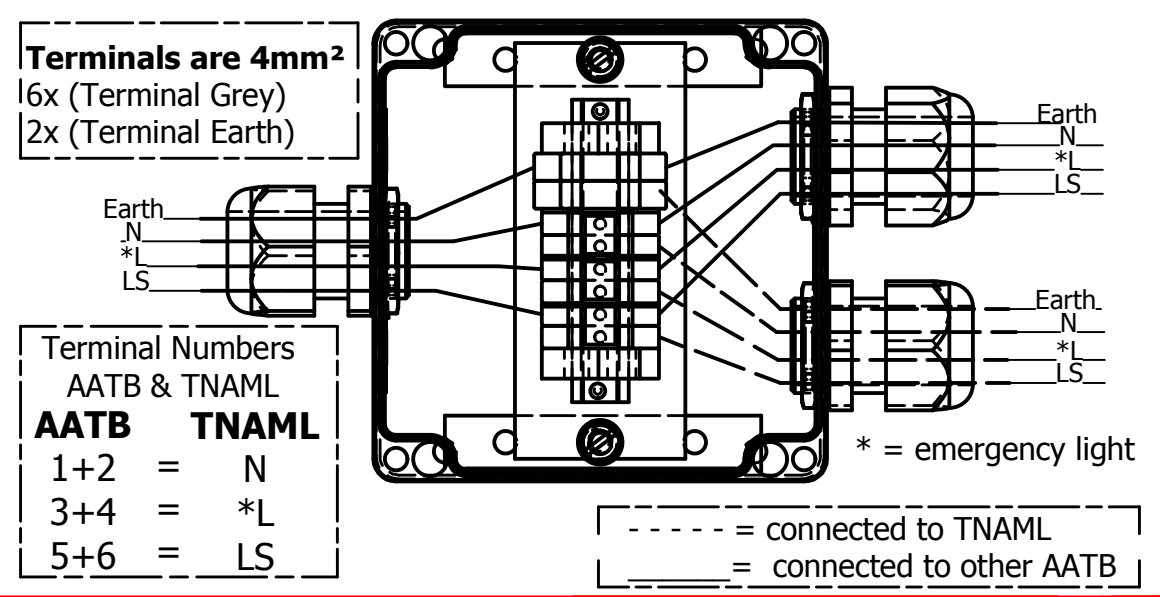

TechNed Benelux B.V.
Veersteeg 15
4212 LR Spijk
The Netherlands

TechNed Benelux B.V.
P.O. Box 9
4170 AA Herwijnen
The Netherlands

Tel. +31 (0)183 631295
Fax. +31 (0)183 631778
Web www.technedbenelux.nl



This drawing is not published. It is the sole property of TechNed® Benelux BV. It is lent to the recipient for his confidential use only and upon the conditions agreements following. In consideration of the loan of this drawing, the recipient promises and agrees to return it upon request and that it shall not be reproduced, copied, lent or otherwise disposed of, directly or indirectly without the written consent of TechNed® Benelux BV not be used in any way to the interest of TechNed® Benelux BV.

00	date	name	order nr. customer:	Reference nr. Techned:	scale	REV: 1
creat.	22-5-17	Y.B.				
check.			Measurement in: mm	Drawn by: Yannick Bor		
			Client:	Drawing number:		Size: A3
				CD.AATB.404_01		
			Projection			
			DIN A3			
1	31-5-17	Adding "Terminal numbers AATB & TNAML"	Y.B.			
RI	date	revision	name	check.on	name	page 1 of 1

AATB Manual Drawing