

LIOL-A LIOL-B



LOW INTENSITY

Low intensity obstruction light multiled type, in compliance with ICAO type A/B, FAA L-810 obstacle, night only.

- Based on LED technology
- Steady burning red light
- Long life time >10+ years expectancy
- Stabilized light output
- Protection degree: IP65
- Weight: 0,6 kg
- Power consumption: 4 W



Order code

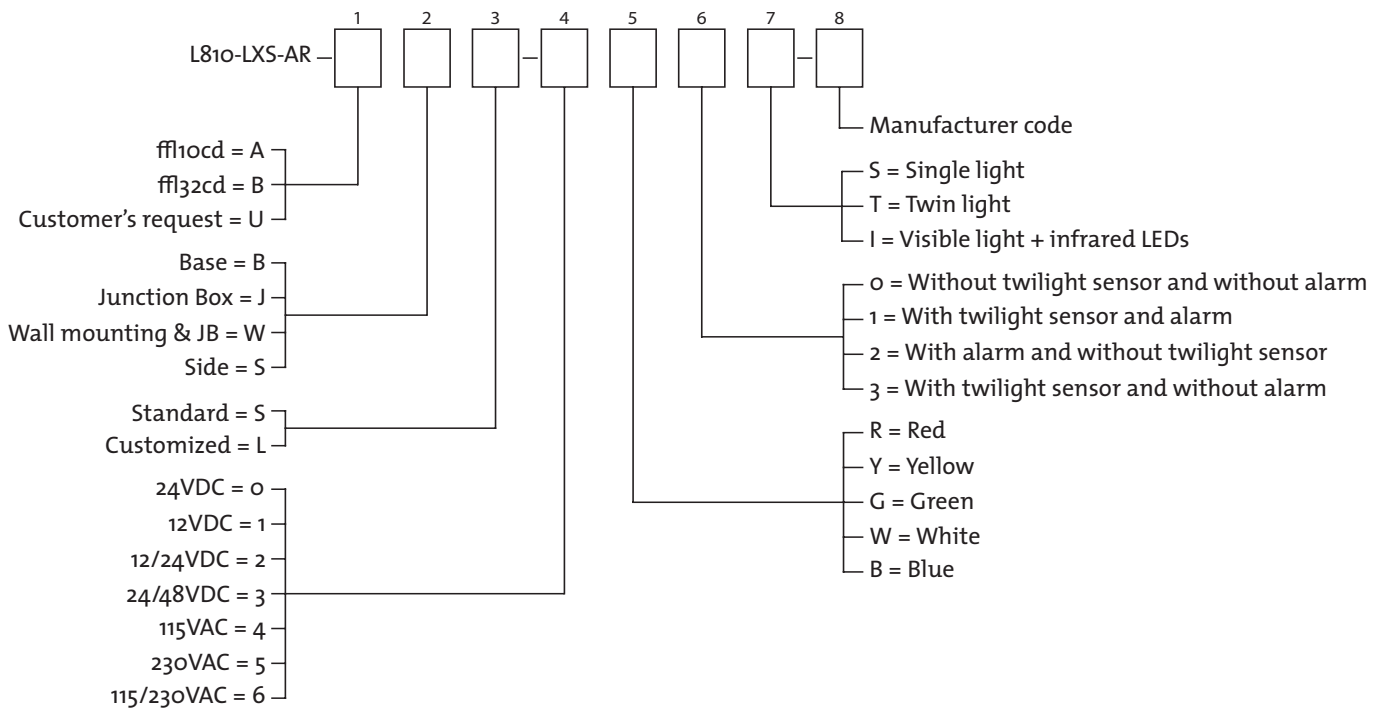

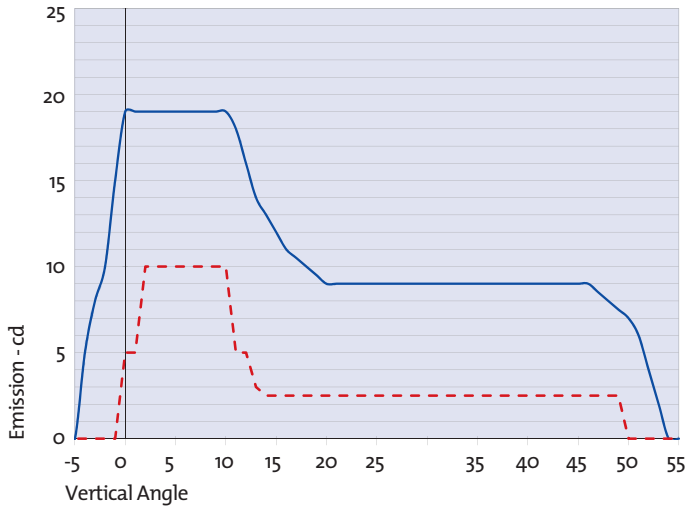

— L810-LXS-A average emission level
 - - ICAO ANNEX 14 low intensity type A Minimum Required Intensity

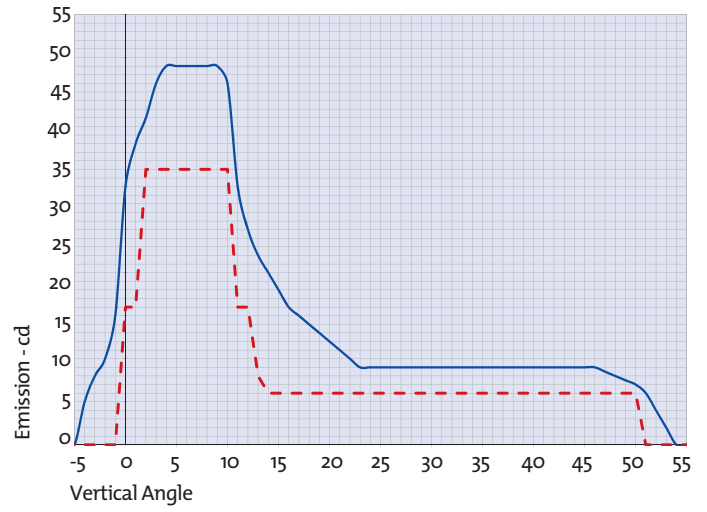

— L810-LXS-B average emission level
 - - ICAO ANNEX 14 low intensity type B Minimum Required Intensity

Order code 2

B = Base

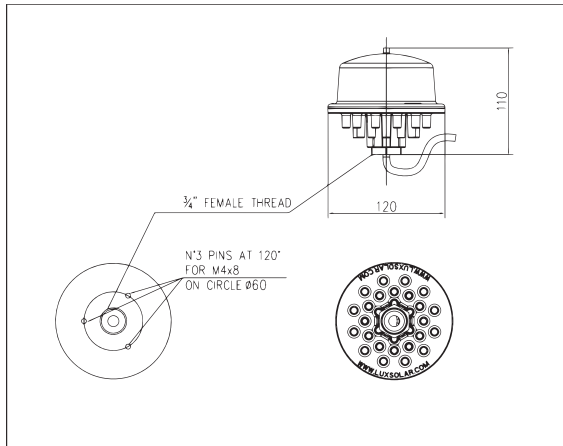

W = JB+S

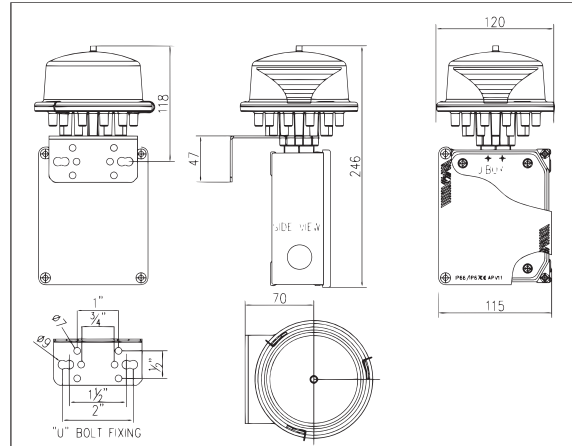

S = Side support plate

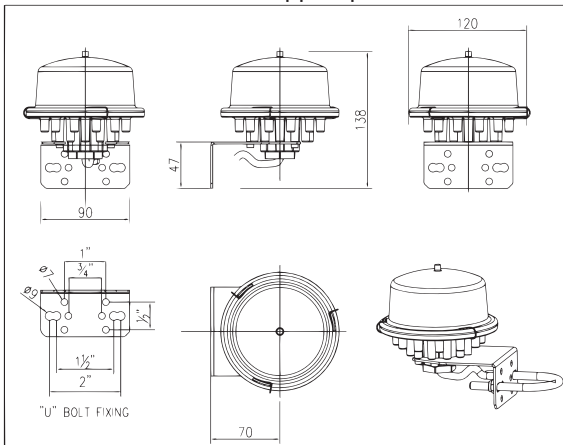

J = With JB

